

SPIRIT

Phase 4 – Motor Testing

Computer and Electronics Engineering

Purpose

You will take electrical measurements on the TekBot to determine the voltage applied to the motors, the current through them, and the results of varying the current through the motors by placing resistors in series with the motors.

Overview

During the course of this exercise you will perform the following tasks:

- Use the DMM to measure voltage and current.
- Learn basic ideas about how a DC motor operates.

Preproject

Be sure your TekBot is fully charged before performing this exercise. To do this be sure that your TekBot has been plugged into the wall transformer for at least 8 hours. If your instructor has not looked at your system yet make sure she does BEFORE you plug it and try to charge it.

Procedure

1. **Resistance:** Unplug the motor cables and measure each motor's resistance with the DMM and record the results in Table 1. Your reading should be around 5-10 ohms.
2. **Voltage:** To measure the motor voltage, the voltmeter is placed in parallel with the motor pins as shown on the right. Plug the power cable (4 pin-2 wire) into the breadboard with the unused pins to the left when viewed from behind. Place the right motor cable into the breadboard so one pin lines up with the power pin and the other lines up with the ground pin. Place a 2 microfarad capacitor in parallel (see photo-Figure 1) with the motor pins. When the motor is running, it creates a lot of arcing and interference. The motor will run properly but the electrical noise will give erratic readings on the digital voltmeter. The capacitor reduces the electrical noise. Place the TekBot

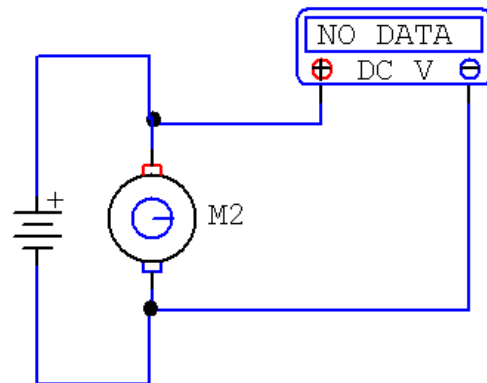

Figure 1

on top of your voltmeter box (or something similar) so that its wheels are elevated. Turn the TekBot ON. The right wheel should turn. Measure the voltage being applied to the wheel by placing one probe of your voltmeter to one lead of the capacitor and the other probe to the other side of the capacitor. Record your reading in Table 1. Your reading should be 5-9 volts depending on the charge level of your batteries. Repeat for the other wheel.

Motor	Resistance	Voltage	Current	Power (Volt*Current)
Left				
Right				

Table 1

3. **Current.** The ammeter must be in series with the battery and motor to measure the current. Move the motor plug one position to the right. Move the capacitor so it is still in parallel with the motor. Place a several inch bare wire in a hole in the same column as the positive (V+) of the power cable and another wire in a hole in the same column as the right motor pin. Set your DMM to the 200 ma scale. Turn the TekBot switch ON. The motor will not turn yet. Press one lead of the DMM to one of the bare wires in the breadboard. Press the other DMM lead to the other wire. This will complete the circuit and the wheel will turn. Your reading should be about 50 ma – 150 ma. Record your results in Table 1. Use your hand to apply some drag to the wheel and observe the change in current. Don't use enough force to stall the motor; you may strip the plastic gears. Repeat the current measurement for the other wheel.

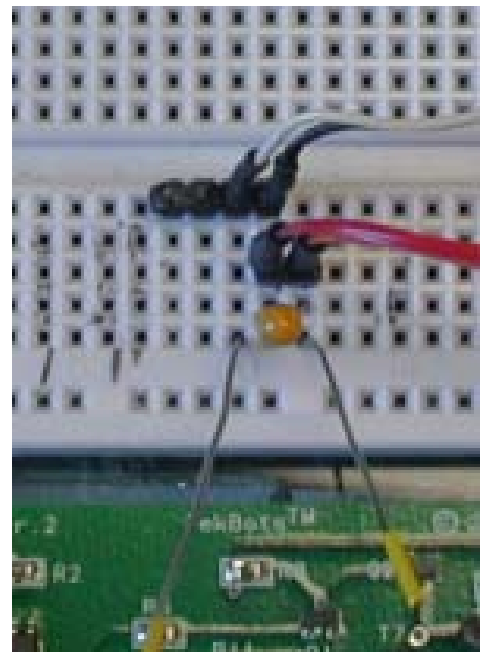
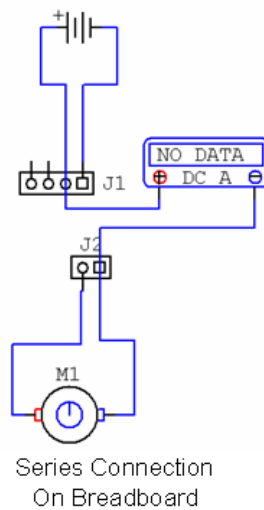
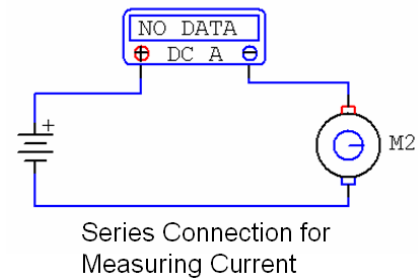
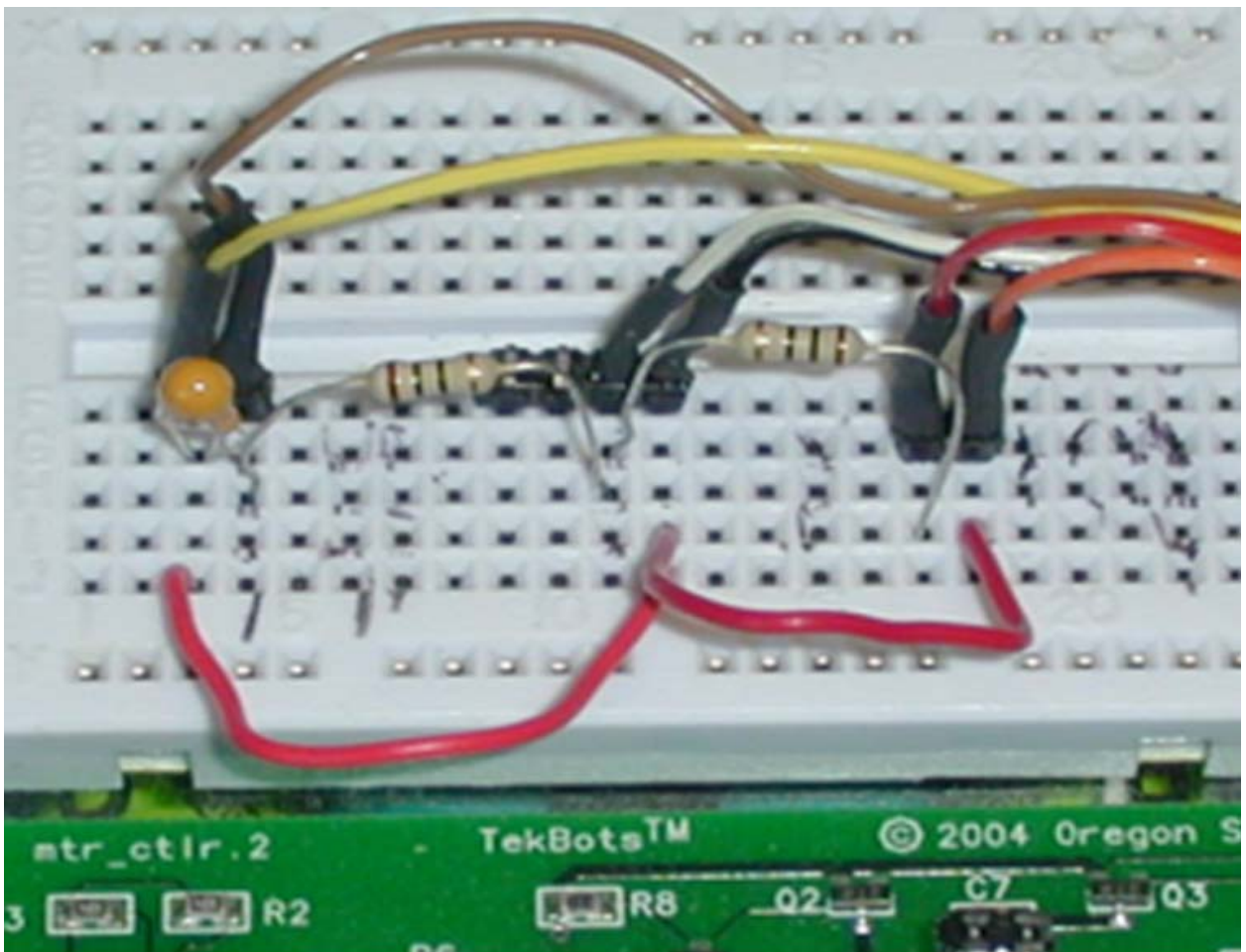

Figure 2

4. Connect the right motor to the breadboard in parallel with the power as shown in Figure 1 on page 1. Connect the left wheel plug in parallel with the right motor plug. Elevate the wheels. Turn the TekBot ON. If both wheels don't turn forward, rotate the motor plugs so that both wheels are going forward. **Change your DMM selector back to Volts. You will blow the fuse if you try to measure voltage on the current scale.** Measure and record the motor voltage in Table 2. Place TekBot on the floor and time how long it takes it to go 10 feet. Each of the floor tiles is 12 inches. Record your results. You may have to nudge your Bot to keep it going straight.
5. Connect 22 ohm resistors in series with each motor as shown in Figures 3 and 4. Measure the voltage of the motor which has the capacitor and record. Measure how long it takes to go 10 feet.



Resistors in Series with Each Motor

Figure 3

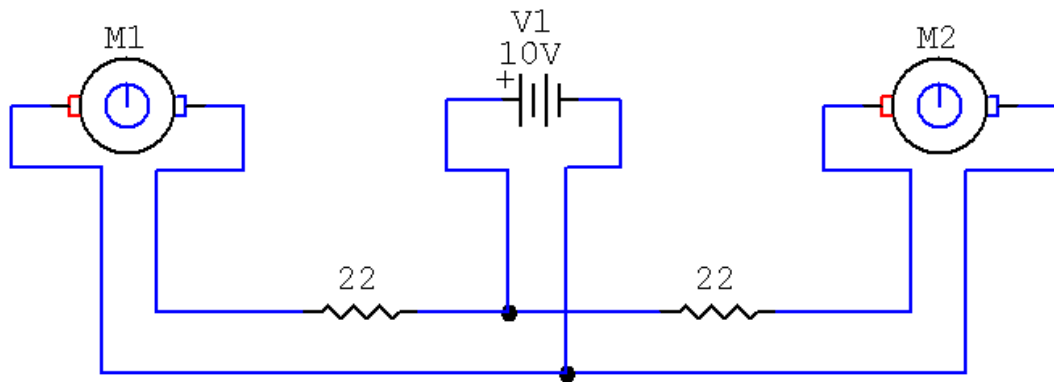
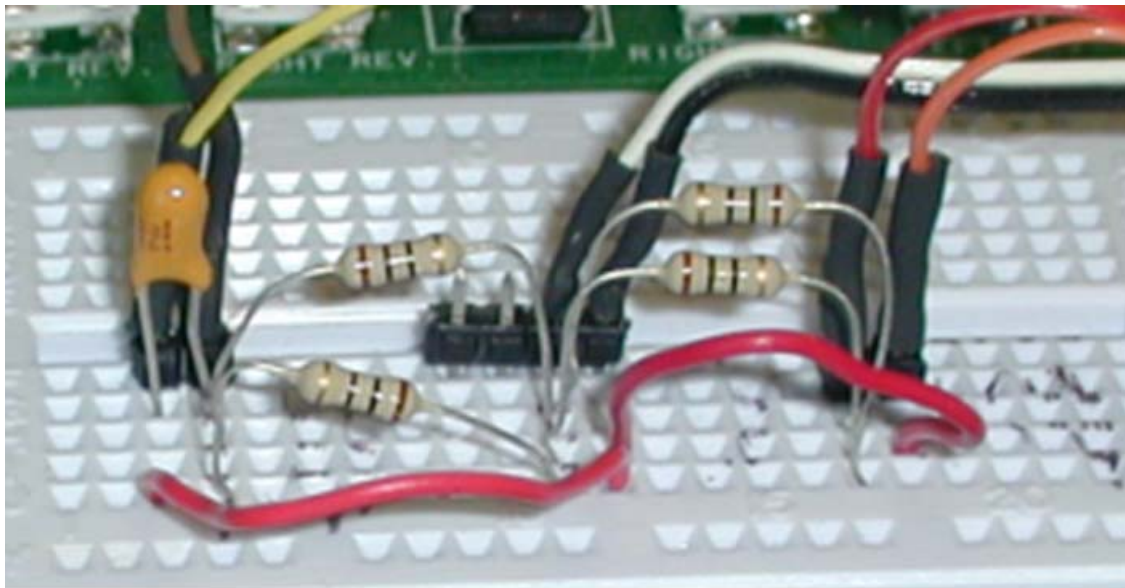

Figure 4. Schematic of Resistors in Series

6. Repeat with 11 ohms by putting two 22 ohm resistors in parallel.



Two Resistors in Parallel

Figure 5

- Use two 22 ohm resistors in series for 44 ohms and repeat the measurements.

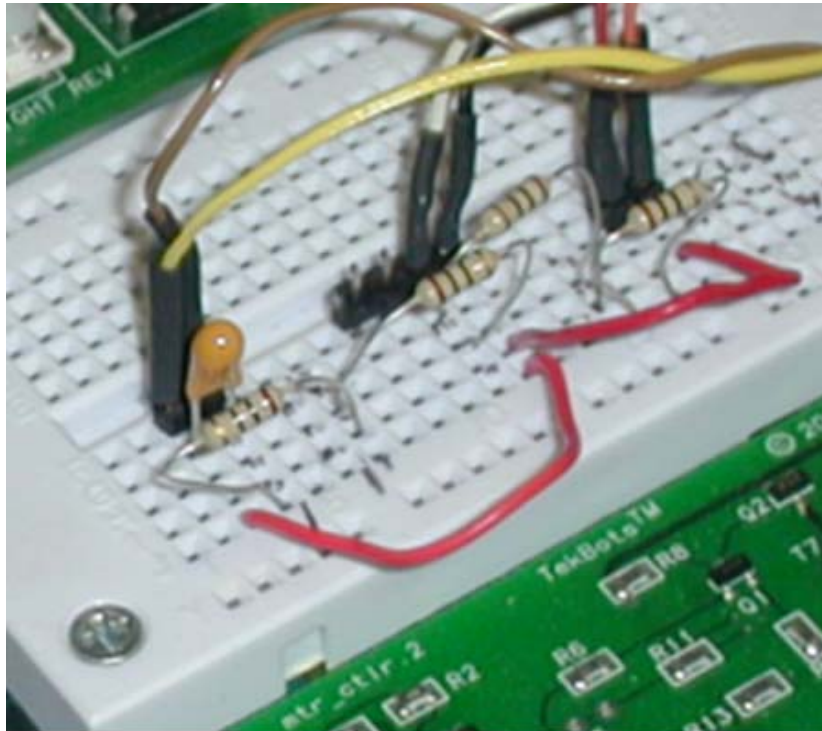

Resistors in Series

Figure 6

Resistance	Voltage Motor (either motor)	Time/ 10 ft
No resistance		
22 ohms		
11 ohms		
44 ohms		

Table 2

- Connect one motor directly across the battery and the other motor in series with 44 ohms resistance. Run the Bot on the floor and measure and record in Table 4 the diameter of the circle traced by the Bot. Repeat with a 22 ohm resistor.

Resistance	Diameter Circle
44 ohms	
22 ohms	
11 ohms	

Table 3

9. With no resistors, place the Bot in the middle of the hallway and observe how far it goes before it hits the wall. _____

TekBot™ is a registered trademark of Oregon State University and the School of EECS.

Copyright C 2007
University of Nebraska

This document is based on documents that are the property of Oregon State University and the School of EECS. Limited use is allowed according to the following criteria; materials are free to use except for cost of reproduction but must bear this statement. Materials created using this information may not be labeled as TekBots materials with out the prior written consent of Oregon State University and the School of EECS.